

The **HORI ELECTROPAK** is a high quality low cost Electric Motor drive power pack. It has been specifically designed for mounting on semi – trailers. It has compact dimensions and low weight. Can be driven in any direction so reverse polarity of electrical supply is no problem. The small dimensions make it easy to install on a semi-trailer. The standard unit is perfect for dry bulk cement discharge.

The strong design is suitable for operations from Africa to Siberia in hot climates and also sub-zero temperatures.

Suitable for: Cement, Flour, Calcium Carbonate, Fly Ash, Hydrated Lime etc.

- ✦ Oil free
- ✦ 2,0 bar (more if required)
- ✦ 550 m³/h
- ✦ Maintenance almost zero
- ✦ Low Noise
- ✦ Bi- Rotational
- ✦ Standard 3 year Warranty
- ✦ 350 kg inc. Accessories
- ✦ Low Cost
- ✦ Low Power 22kW max

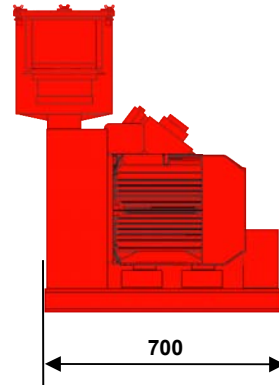
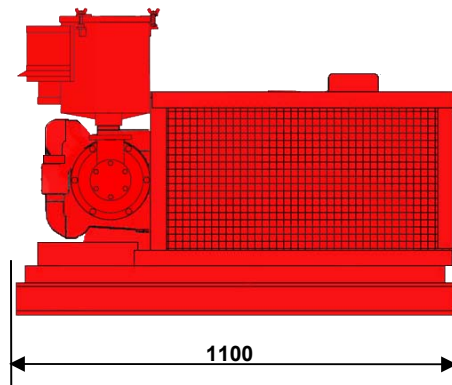

Description	Unit	Details
Flow at inlet (2,0 bar)	m ³ /h	550
Motor	rpm	1460
Working Pressure	bar (g)	max. 2,5 bar
Power consumption (2,0 bar)	kW	22 max.
Voltage	380 – 400volts	3 phase
Dimensions	mm	700 x 1100 x 900
Weight inc. accessories	kg	350

Benefits	Advantages
✧ Oil free	✧ Low noise
✧ 2,0 bar (more if requested)	✧ Low power
✧ Bi – rotation any polarity	✧ Low weight
✧ Oil change 1 time per year (common motor oil)	✧ Low maintenance
✧ No other maintenance	✧ Low bearing rpm
✧ Standard 3 year guarantee	✧ Low rotor rpm
✧ Long bearing life	✧ Low cost